

SWP01-Pull down basket



1. One, selection of product specifications and models

Required dimensions of cabinet : 16mm ~ 18mm

A. Upturn door structure

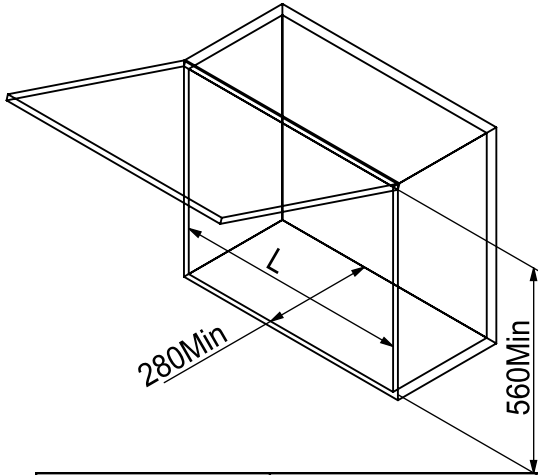

B. Double-door structure

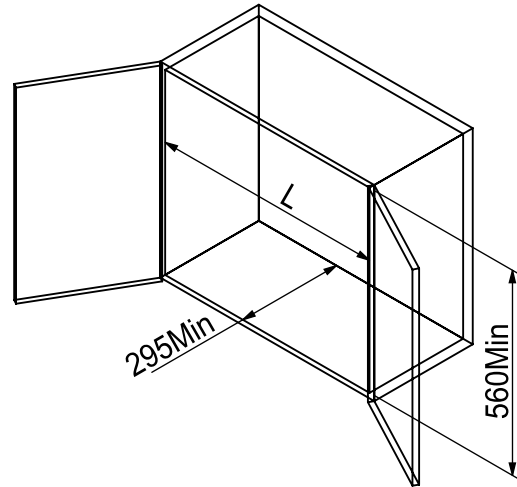

Cabinet width	Clear width "L" (mm)
600 Cabinet	564~568
700 Cabinet	664~668
750 Cabinet	714~718
800 Cabinet	764~768
900 Cabinet	864~868

2. Fixing steps

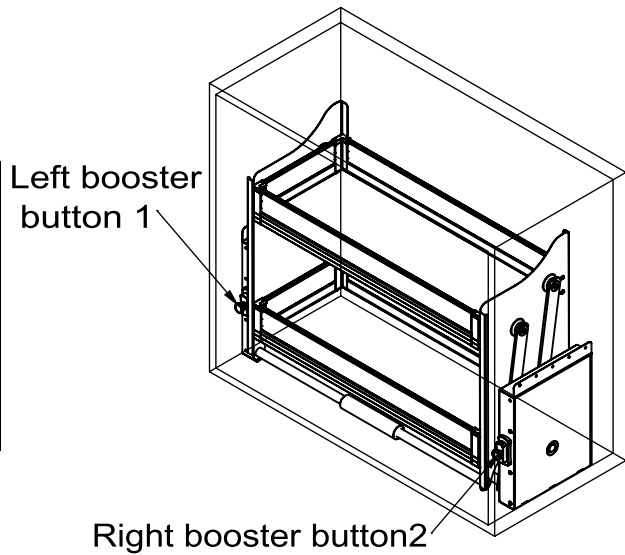
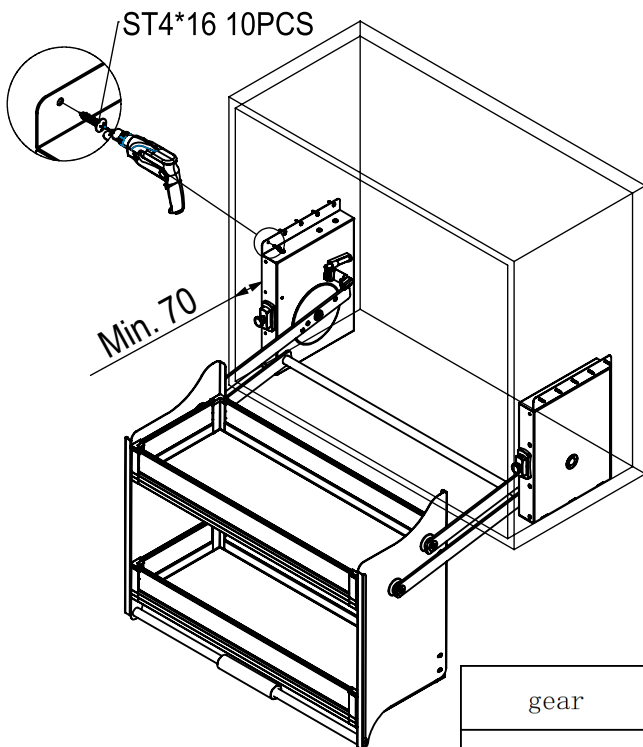

gear	the state of booster buttons	loaded weight
slot	both booster buttons are pressed in	0~2kg
first gear	Pull out the left button 1 and press in the right button 2.	2~5kg
second gear	Press the left button 1 and pull out the right button 2	5~7kg
third gear	Pull out both buttons	7~12kg